

No. 662,835.

Patented Nov. 27, 1900.

J. & W. R. THOMAS.
MANDREL.

(Application filed Sept. 24, 1900.)

(No Model.)

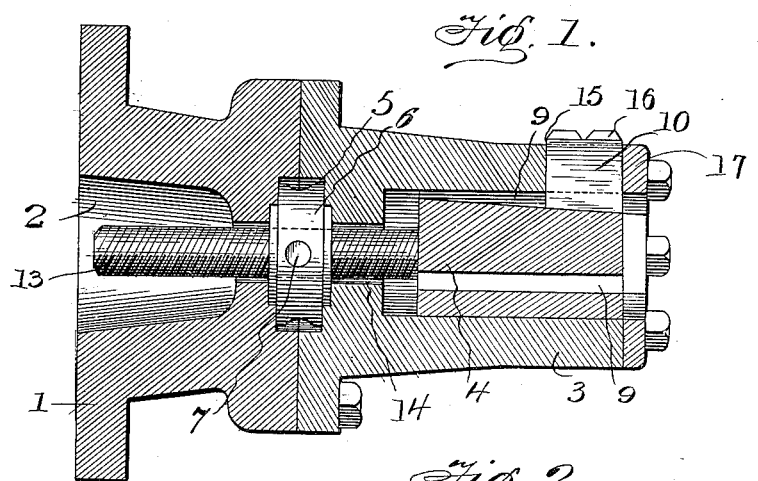

Fig. 1.

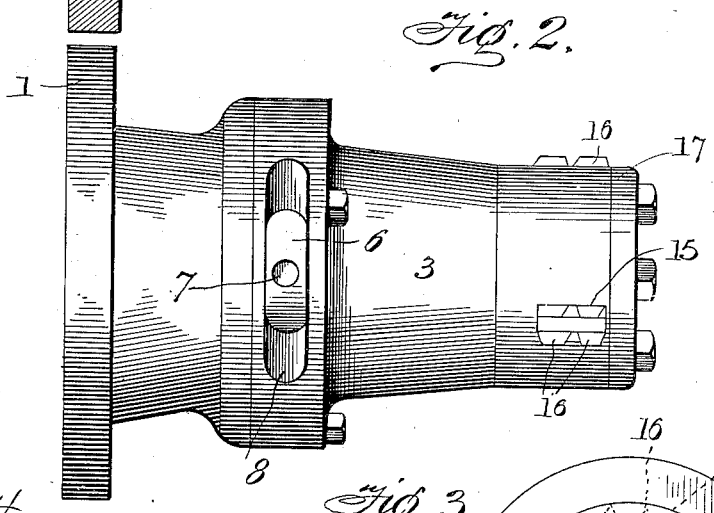

Fig. 2.

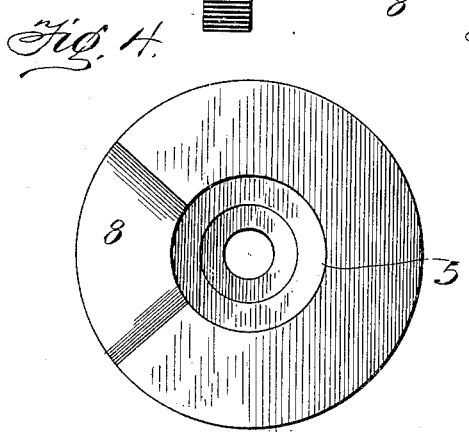

Fig. 4.

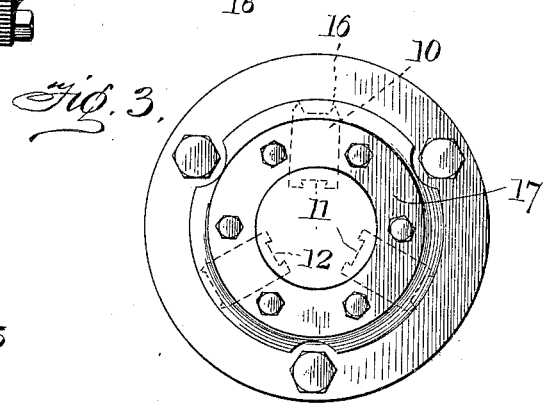

Fig. 3.

Witnesses
Fenton S. Bell,
East Hingham.

Inventor,
James Thomas, and
William R. Thomas.

Norton Fenwick Lawrence
 224
 Attorneys

UNITED STATES PATENT OFFICE.

JAMES THOMAS AND WILLIAM R. THOMAS, OF CATASAUQUA, PENNSYLVANIA.

MANDREL.

SPECIFICATION forming part of Letters Patent No. 662,835, dated November 27, 1900.

Application filed September 24, 1900. Serial No. 30,959. (No model.)

To all whom it may concern:

Be it known that we, JAMES THOMAS and WILLIAM R. THOMAS, citizens of the United States, residing at Catasauqua, in the county of Lehigh and State of Pennsylvania, have invented certain new and useful Improvements in Mandrels; and we do hereby declare the following to be a full, clear, and exact description of the invention, such as will enable others skilled in the art to which it appertains to make and use the same.

Our invention relates to improvements in mandrels, and particularly to the class of mandrels which are capable of expansion.

The object of the invention is to provide an improved mandrel of simple and economic construction, which shall be easy to operate and not liable to breakage or undue wear by ordinary usage.

With this object in view the invention consists in the improved construction, arrangement, and combination of parts hereinafter fully described and afterward specifically claimed.

It further consists in certain other novel constructions, combinations, and arrangements of parts, as will be fully described and claimed.

In the accompanying drawings, forming a part of this specification, Figure 1 represents a longitudinal vertical central section through our improved mandrel. Fig. 2 represents a top plan view of the same. Fig. 3 is an end view of the said mandrel. Fig. 4 is an end view of the supporting-base, showing the opening through which the mandrel may be operated.

The mandrel forming the subject of the present application is designed for holding articles which are to be faced or turned and is adapted to be inserted into the end of such an article and clamped therein.

In embodying the invention in practical form we provide a base piece or plate 1, which is adapted to be secured in any suitable manner to the face-plate of a lathe or other machine, and is provided with a central opening, as at 2, to receive the mandrel-screw. Bolted to the face of the base 1 is a jaw-casing 3, which is hollow and formed in such a manner as to accommodate the mandrel proper, 4. An enlarged space, as at 5, is formed between

the base 1 and the casing 3 to receive a nut 6, which is adapted to engage the mandrel-screw and to move the same back and forth. This nut is preferably circular in shape and is provided with a series of peripheral holes or recesses 7 7, into which a rod or bar may be inserted for turning the said nut. In order to reach this nut with such an operating-rod, we form in the meeting faces of the base 1 and the casing 3 a flaring opening, as 8, the said opening being made sufficiently elongated to permit of sufficient movement of the said rod in turning the said nut.

The mandrel proper, 4, is formed with a series of inclined grooves or ways 9 9, which are adapted to engage jaws 10 10. The said jaws may engage a smooth groove 9 or may be dovetailed, as seen at 11 in Fig. 3 of the drawings, and engage a correspondingly-shaped dovetailed rib or projection 12, formed upon the mandrel. By moving the mandrel outwardly the jaws 10 may be caused to ride up the inclines of the grooves 9, and the said jaws will thus be forced outwardly, so as to grip any article which is inserted over the end of the mandrel. The mandrel 4 is operated by means of a mandrel-screw 13, which passes through an opening 14 in the casing 3 and engages the threads of the nut 6, so that when the said nut is turned the screw and mandrel carried thereby may be forced back and forward to operate the jaws 10. The jaws 10 are inserted in recesses 15 15, formed in the casing 3, their outer ends projecting beyond said casing and being provided with gripping projections or teeth, as 16 16. The said jaws 10 are held in position in the recesses 15 by means of an end ring-plate 17, which is bolted or otherwise secured to the end of the casing 3. The jaws are held from falling out of position by the said ring 17 and also by the dovetailed joint formed at 11 and 12.

In using the mandrel the article to be operated upon is placed over the end of the casing 3 and the screw 13 is then pulled outwardly by operating the nut 6, the mandrel thus in its outward movement operating to force the jaws 10 outwardly and into firm engagement with the inner surface of the article acted upon.

A mandrel constructed in this manner is not only useful for holding a body to be turned,

but makes it possible to face the body or article upon two ends at the same time. The mandrel is simple in construction and not likely to get out of order. The mandrel can
5 be moved outwardly through the opening in the ring 17 as far as necessary to bring the jaws in contact with the article to be turned or faced.

Having now described the invention, what
10 is claimed as new, and desired to be secured by Letters Patent, is—

15 An expanding mandrel comprising a base, a jaw-casing secured thereto, the said base and casing having an opening formed between them for receiving a revolving nut, and an elongated segmental opening formed between them to accommodate an operating lever or rod for turning said nut, a screw en-

gaging the internal threads of the said nut, a mandrel carried upon the inner end of said 20 screw and arranged within a recess in the jaw-casing, jaws mounted in recesses in said casing and engaging inclined dovetailed ways formed upon the said mandrel, gripping-teeth 25 formed upon the said jaws, and a ring or plate secured to the end of the said jaw-casing for holding the jaws in proper position, substantially as described.

In testimony whereof we hereunto affix our signatures in presence of two witnesses.

JAMES THOMAS.

WILLIAM R. THOMAS.

Witnesses:

HOPKIN THOMAS,

R. E. WILLIAMS.